

SMART IO'S:

ABOUT:

These modules are designed to cater to the following needs:

- 1) Cost effective expansion of existing PLC system.
- 2) Cost effective control of remote field devices.
- 3) Control of field devices from personal computer.
- 4) Data acquisition.

FEATURES:

- Supports Modbus communication protocol
- Works as slave with PLC master
- Communication over RS232/485 bus
- 2500VAC isolation between 485 link and station circuit.
- Slave address and baud rate selectivity via 485 bus.
- Links upto 4000ft(1.2KM) long possible.
- Onboard SMPS works from 90 to 270VAC.
- Models available with Onboard DC-DC converter which works from 18 to 36VDC
- Response time <50msec.
- Low cost.
- 35 mm DIN rail mountability.

MODELS AND SPECIFICATIONS:

1) 8 CHANNEL MODBUS RELAY OUTPUT MODULE:

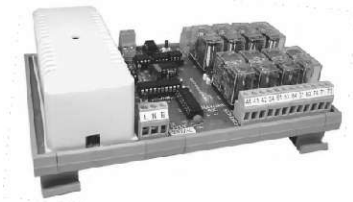

Weight(W) : 185mm(max)
Height(H) : 115mm(max)
Depth(D) : 80mm(max)

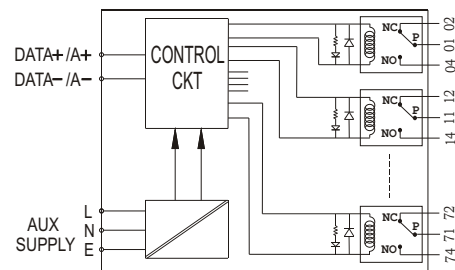

This module has 8 single change over onboard relays with contacts taken out for field devices. Each relay has unique coil address which is used to force relay on/off. The coils can be made on/off individually or in combination using Modbus commands.

2) DIGITAL KEY INPUT MODULE:

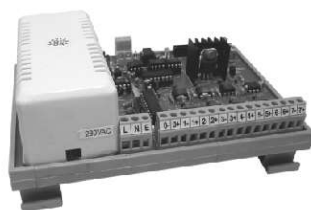

Weight(W) : 185mm(max)
Height(H) : 115mm(max)
Depth(D) : 80mm(max)

Internal 24V supply also available. Looping of +Ve or -Ve to be done as required.

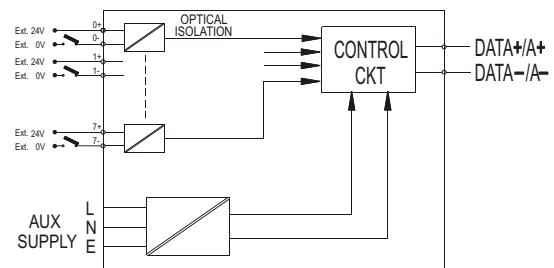

This module has processor which continuously scans the 8 digital key inputs and sends the status of keys to master when read query from master is detected.

3) COMBO MODULE:

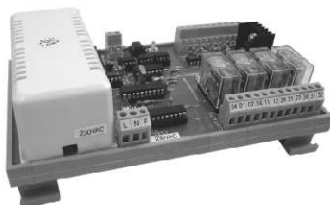

Weight(W) : 185mm(max)
Height(H) : 115mm(max)
Depth(D) : 80mm(max)

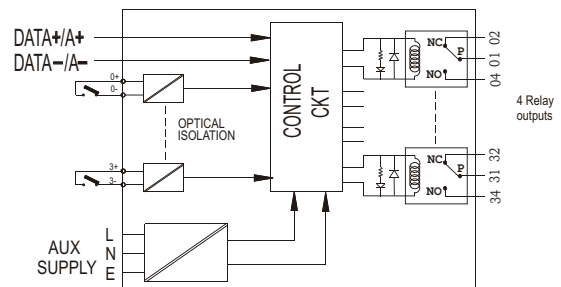

This module comprises both input and output. It has 4 relay outputs and 4 digital key inputs.

4) ANALOG INPUT/OUTPUT MODULE:

Under development

The analog input module accepts the analog inputs such as 4-20mA 0-10Vdc, inputs from thermocouple, RTD, LoadCell, etc, converts it to digital and sends it to master PLC/PC for control.

MODBUS COMMUNICATION PROTOCOL:

The tree given here explains the various fields of Modbus query with parameters supported by SMART I/O's.

01 05 00 01 00 01 XX XX

SLAVE ADDRESS: This byte of the query is the slave address of the relay module. This can have any value from 1-247(dec) .See page. 4 .

FUNCTION CODE: This byte of the query is the Modbus Function Code. This SMART I/O module supports 4 function codes:
 05h:Force single coil ON/OFF ;for output/combo module
 06h: Preset single register ;for output/input/combo module
 0Fh:Force multiple coils ON/OFF ; for output/combo module
 04h:Read input register. ; for input module

When function code =05h BIT OPERATION	These two bytes of the query represents the 16 bit address(in hex) of the coil to be made on/off. Refer table.1 for coil addresses.
When function code =06h WORD OPERATION	In word operation , this word represents the 16 bit internal holding register address, the value of which decides relays to be ON/OFF in combination OR in program mode , this word represents the 16 bit internal holding register address of smart i/o to which slave address and baud rate values are written. Refer table.3 for values and explanation..
When function code =04h READ OPERATION	In read operation ,this word represents the 16 bit internal holding register address, which holds the key status read from terminals. Refer table.3 for values and explanation.

When function code =05h BIT OPERATION	In bit operation, these two bytes of the query represents commands to make coil ON/OFF. 0001:coil ON and 0000: coil OFF
When function code =06h WORD OPERATION	This word represents the value to be written to holding register specified in query. In word operation , the lower byte of this word represents value which is used for making relays ON/OFF in combination. For example, if this word is 0007h,then lower byte is 07h i.e 00000111 in binary. Hence first three relays will be forced ON and others OFF. In Program mode, the lower byte of this word contains the value of slave address or baud rate.
When function code =04h	In read operation ,this word represents number of bytes being read from SMART I/O. This is fixed to 0001 since only one value is being read.

The last two bytes of the query from master are the check sum (CRC) bytes used for error detection by PLC master and slave.

MODBUS MASTER QUERY CONFIGURATION:

1)QUERY FOR DIGITAL OUTPUT(FORCE COIL ON/OFF):

QUERY FOR SINGLE COIL ON/OFF :

01 05 10 07 00 01 XX XX

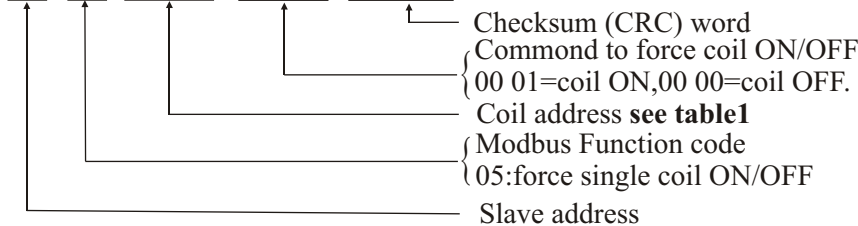

RESPONSE: Response to the above query will be the same frame as received and is sent after action has been taken i.e.. Coil has forced ON/OFF

COIL ADDRESSES:

RELAY NO.	COIL ADDRESS(HEX)
RL0	1004
RL1	1005
RL2	1006
RL3	1007
RL4	1008
RL5	1009
RL6	100A
RL7	100B

Table.1

QUERY FOR WORD OPERATION : For word operation, the query to make multiple relays ON/OFF will be:

01 06 10 00 00 07 XX XX

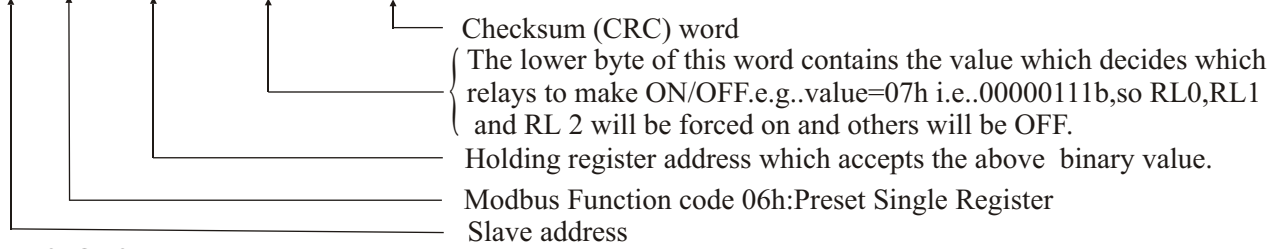

RESPONSE: Response to the above query will be the same frame as received and is sent after action has been taken i.e. Coils has forced ON/OFF.

2) QUERY FOR DIGITAL/ANALOG INPUT MODULE (READ KEY STATUS/READ ANALOG VALUE)

01 04 10 03 00 01 XX XX

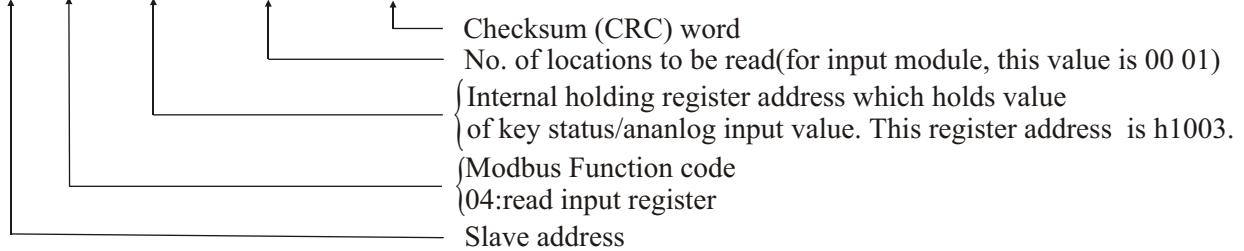

RESPONSE: The slave response to the above query will be as below:

01 04 02 FF FE XX XX

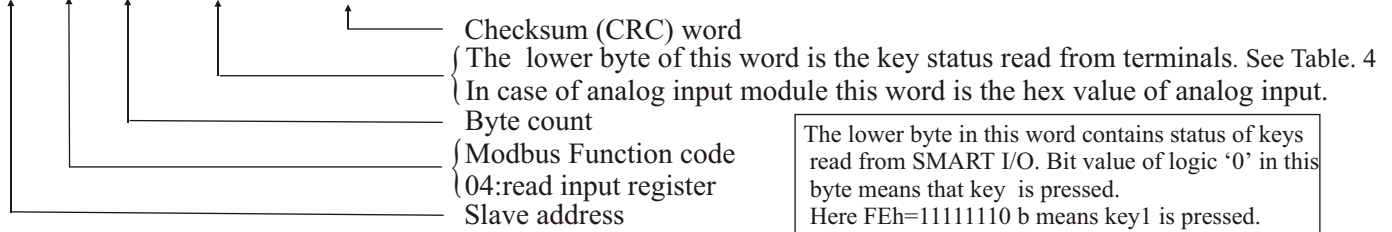

EXCEPTION RESPONSES AND EXCEPTION CODES:

TABLE. 4

In normal communication, the PLC master device sends the query to SMART I/O and SMART I/O receives query without communication error and handles the query within master devices allowable timeout. The abnormal communication will take place when 1) Slave receives the function code which it does not support. 2) The coil/holding register address received in query is not a valid address.

The exception response message has two fields that distinguishes it from normal response as below:

01 85 01 XX XX

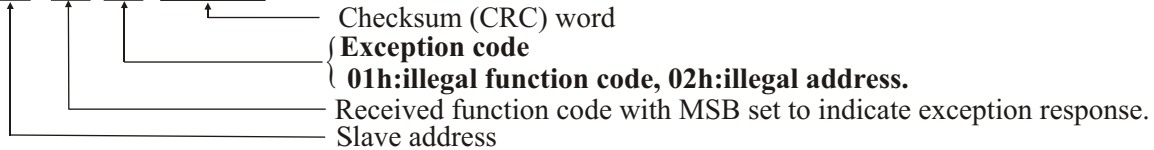

NETWORK CONFIGURATION:

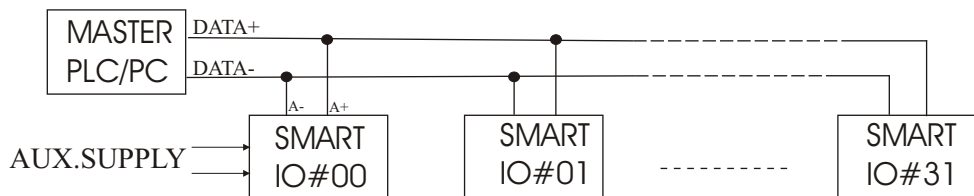

SLAVE ADDRESS AND BAUD RATE PROGRAMMING:

The SMART I/O's has the facility to set the slave address and communication baud rate as required during commissioning and installing through the PLC via 485 bus. See the queries below

The slave address value can be written to the internal holding register addressed at location h1001.

The baud rate value can be written to the internal holding register addressed at location h1002.

The acknowledge from SMART I/O when it enters into program mode is indicated by RED LED (closer to L N E) on board. This LED goes permanent high at start of this mode. When both parameters i.e.. Slave address and baud rate are written to holding register the LED goes low to indicate completion of program mode.

- IMPORTANT NOTE:**
- The factory/default values of slave address and baud rate are 01h and 9600 bps. Once these values are changed ,the default values can be reloaded by pressing the **PROGRAM SWITCH** on board for about 5 seconds during power on reset.
 - Once the required values of slave address and baud rate are written to the smart io, for these values to take effect, switch off the module for 5 seconds and power-up again. The module will now work with programmed values.

- The query to change the value of slave address is:

01 06 10 01 00 05 XX XX

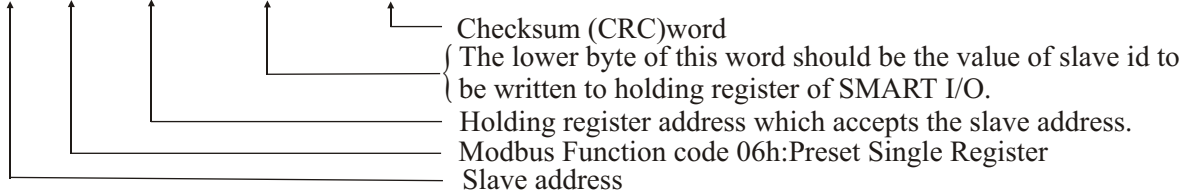

RESPONSE: Response to the above query will be the same frame as received and is send after value is written to slave memory.

Slave address value can have value from 1--247(decimal) and is written to holding register at h1001.

- The query to change the value of baud rate is:

01 06 10 02 00 FA XX XX

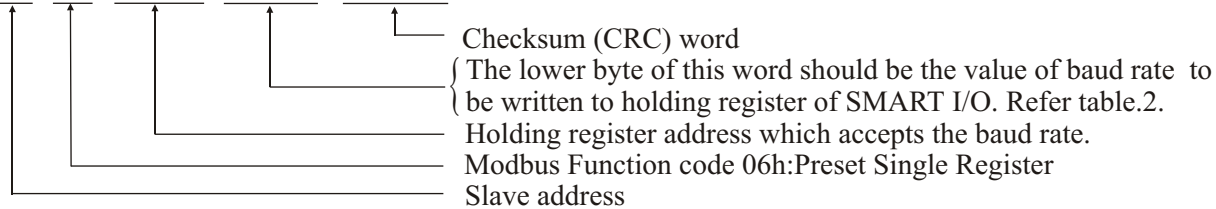

RESPONSE: Response to the above query will be the same frame as received and is send after value is written to slave memory.

Values to be written to SMART I/O at address h1002 to set the baud rate to required:

VALUE (HEX)	BAUD RATE
F0	19200bps
FD	9600bps
FA	4800bps
F4	2400bps
E8	1200bps

Table.2

INTERNAL HOLDING REGISTER ADDRESSES:

HOLDING REGISTER ADDRESS (HEX)	REFERENCED TO SMART I/O
H1000	Used by slave to store word from master in word operation
H1001	Holds the value of slave address received during program mode
H1002	Holds the value of baud rate received during program mode
H1003	Holds the value of key status read from terminals In input module

Table.3

SAMPLE PROGRAM:

To make coil of address h1007 ON

**Program for LG PLC,
Model:MASTER-K80S,K7M-DT10S**

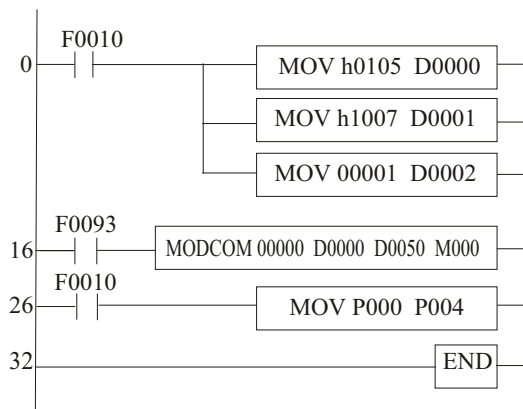

TROUBLESHOOTING:

If the SMART I/O is found not functioning:

- * Check all connections first i.e.. 485+ signal from PLC master is connected to A+ of SMART I/O and similarly for 485-.
- * Check the auxillary supply for recommended voltages.

In normal communication, the RED LED(on supply side) on the board is used to indicate the mode in which module is working. In normal case, when SMART I/O receives query from PLC master, this LED goes high and when SMART I/O sends the response it goes low.

In program mode, this LED goes permanent high. When the two parameters i.e.. SLAVE ADDRESS and BAUD RATE are written to slave, the LED goes low to indicate end of program mode.